

Electro-spindle& patent clamping device



CSL075 5 axes without back spindle



CSL076 with back spindle(Z2 axes)



CSL076 inside

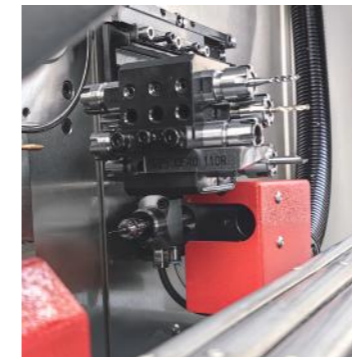

Super high speed live tool



SYNTEC 220TB PLUS CNC controller

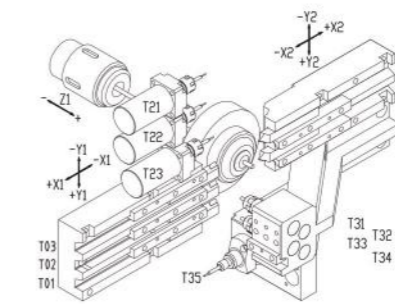

CSL075 tools distribution

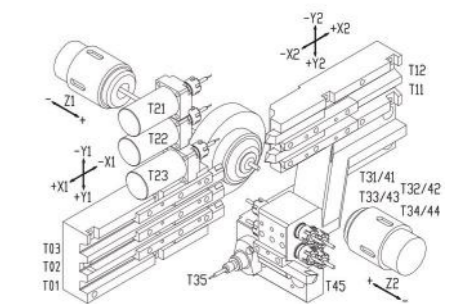

CSL076 tools distribution

### Features:

- Especially suitable for microminiature workpiece machining(1~10mm)
- Adopt similar structure as SWISS & JAPANESE machine
- Adopt SWISS technology, most parts adopt GERMANY/JAPAN/TAIWAN brand
- X1/Y1 and X2/Y2 axes can work independently, can realize simultaneous rough& finish turning
- Can easily shift between "fixed guide bushing" and "rotary guide bushing", only need approximate 15 minutes
- Main spindle standard mount 3pcs high speed(12000rpm) radial type live tools
- Leave installment position for 5000~60000rpm super high speed live tool (brushless high speed electro-spindle)
- Adopt patent design for parts catching: oil mist & air blowing mixed
- Adopt patent design for clamping by built-in type hollow air cylinder
- Adopt compact hanging type oil coolant system for spindle coolant
- Adopt high precision built-in electro-spindle, NSK super high precise angle bearing, achieve spindle's high precision retention
- After mount automatic bar feeder, can realize automatic machining

### Main parts list:

Item	Brand	Item	Brand
CNC controller	TAIWAN-SYNTEC	Ball screw	JAPAN-THK
Servo electro-spindle	OWN-MADE	Linear guideway	TAIWAN-CSK
Servo motor&driver	TAIWAN-SYNTEC	Lubrication system	JAPAN-HERG
Spindle encoder	TAIWAN-SYNTEC	Main electricity parts	FRANCE-SCHNEIDER
Spindle bearing	JAPAN-NSK	Pneumatic parts	TAWAN-AIRTAC
Ball screw bearing	JAPAN-NSK		

### Standard configuration:

- SYNTEC 210TB-E/220TB CNC controller
- Fixed guide bushing
- Parts catcher
- Spindle oil cooler

### Optional configuration:

- Oil mist collection system
- Rotary guide bushing
- Bar feeder

SWISS TECHNOLOGY, 5/6 AXES, FOR MICROMINIATURE WORKPIECE

**Specification:**

Item	Specification	Unit	BL-CSL075	BL-CSL076		
Capacity	Max. machineable bar dia.	mm	Φ7(can extend to Φ10 for alloy copper& alloy aluminium)			
	Min. machineable bar dia.	mm	Φ1(need to mount especial option)			
	Main spindle bore	mm	Φ14			
	Max. machineable length	Fixed guide bushing	mm	120		
		Rotary guide bushing	mm	55		
Guide bushless		mm	(2~3)×ΦD,max.15~20			
Main spindle	Main spindle type	/	Servo oil-cooling electro-spindle			
	Main spindle max speed	rpm	15000(regular using: < 12000)			
	Main spindle power	kw	2			
	Main spindle index	/	CS axes(continuation),electromagnetic brake			
	Main spindle axial static type drilling tool	mm	4×ER11			
	Main spindle max. face drilling dia.	mm	Φ5(alloy copper)			
	Main spindle max. face tapping dia.	mm	M4(alloy copper)			
	X1 axes (left side)	O.D. turning tool	mm	3×□10		
		Radial type live tool		2×ER11(shifting 2.5mm, max. clamping dia.:4mm,suitable for tapping&tapping) +1×ER11(shifting 13.5mm,max. clamping dia.:4mm, suitable for Φ24~25mm groove sawing) Shifting means distance from live tool center line to collet face		
			Radial type live tool max speed	rpm	12000(regular using: < 10000)	
			Radial type live tool power	kw	0.4	
		Radial type live tool max. drilling dia.	mm	Φ4(alloy copper)		
		Radial type live tool max. tapping dia.	mm	M3(alloy copper)		

**Specification:**

Item	Specification	Unit	BL-CSL075	BL-CSL076	
Main spindle	X2 axes (right side)	O.D. turning tool	mm	2×□10	
		Radial type live tool	mm	1×ER8(shifting 2.5mm, max. clamping dia.:4mm,suitable for drilling&tapping/ shifting 13.5mm,max. clamping dia.:4mm, suitable for Φ24~25mm groove sawing/ shifting 63mm,max. clamping dia.:4mm,suitable for back spindle's radial microholes drilling&tapping)* Shifting means distance from live tool center line to collet face	
	Radial type live tool max speed	rpm	5000~60000(brushless high speed electro-spindle)*		
	Radial type live tool power	kw	0.15*		
	Radial type live tool max. drilling dia.	mm	≤Φ1*		
	Axial type live tool max speed	rpm	5000~60000(brushless high speed electro-spindle)*		
	Axial type live tool power	kw	0.15*		
Back spindle (Z2 axes)	Back spindle type	/	/	Servo oil-cooling electro-spindle	
	Back spindle max speed	rpm	/	15000(regular using ≤12000)	
	Back spindle power	kw	/	1	
	Back spindle index	/	/	CS axes(continuation), electromagnetic brake	
	Back spindle axial static type drilling tool	mm	/	4×ER11(share with main spindle)	
	Back spindle max. face drilling dia.	mm	/	Φ5(alloy copper)	
	Back spindle max. face tapping dia.	mm	/	M4(alloy copper)	
	Back spindle O.D. turning tool	mm	/	1×□10	
	Back spindle max. workpiece insert length	mm	/	15	
	Back spindle max. workpiece catching length	mm	/	40	
Others	Rapid moving speed	m/min	30		
	Repeat positioning accuracy	mm	≤0.003		
	X1/Y1/Z1/X2/Y2/Z2 axes motor	kw	0.75/0.75/0.75/0.75/0.75/None(SYNTEC)	0.75/0.75/0.75/0.75/0.75/0.4(SYNTEC)	
	Coolant pump	kw	0.2		
	Lubrication pump	w	25		
	Total power	KVA	6		
	Overall size	mm	1790×1260×1700		
N.W.	kg	1300	1600		

\*As option